

DET KGL. DANSKE VIDENSKABERNES SELSKAB
MATEMATISK-FYSISKE MEDDELELSER, BIND XX, Nr. 11

THE DECAY CONSTANT OF RaC'

BY

J. C. JACOBSEN AND TH. SIGURGEIRSSON



KØBENHAVN

I KOMMISSION HOS EJNAR MUNKGAARD

1943

Printed in Denmark.
Bianco Lunos Bogtrykkeri A/S

The determination of the decay constant of RaC' has been the subject of several investigations ^{1, 2, 3, 4, 5}. A considerable accuracy was obtained in the experiments of DUNWORTH⁴ and of ROTBLAT⁵ in which the ROSSI method of detecting coincidences was used. By this method, small time differences are determined by measuring the change occurring in the number of coincidences between two counters, when the resolving power of the circuit is changed.

The applicability of this method is restricted to time intervals from about 10^{-2} to 10^{-6} sec. In ROTBLAT's experiments, the resolving time was changed by changing the grid leak of one of the valves in the ROSSI circuit and, as a lower limit for the resolving time, $6 \cdot 10^{-5}$ sec was found. A lower limit of the order of magnitude 10^{-6} sec is apparently inherent in the use of counters and may be ascribed to a variable time difference between the arrival of the primary particle and the start of the discharge. It is not quite clear how the time difference can attain a value as high as 10^{-6} sec. If it is assumed that the discharge starts when a secondary electron arrives at the central wire, a variable time lag will result if the primary particle passes through the counter at different distances from the central wire. Under ordinary working conditions, the passage of an electron from the wall of the counter will, however, last about 10^{-8} sec, only, so that some other mechanism in the building up of the discharge must be responsible for the limitations of the resolving time actually found.

¹ JACOBSEN, Phil. Mag. XLVII, 23, 1924.

² BARTON, Phil. Mag. VII, 2, 1926.

³ JACOBSEN, Nature 133, 565, 1934.

⁴ DUNWORTH, Nature 144, 153, 1939.

⁵ ROTBLAT, Proc. Roy. Soc. 177, 260, 1940.

⁶ ROTBLAT's paper was not available to us before the present work was completed in the summer of 1942.

The time interval between the emission of a β -particle from RaC and the accompanying α -particle from RaC' is of the order 10^{-3} to 10^{-4} sec. In the present experiments, the Rossi coincidence circuit is used with a constant resolving time, and the impulses from the β - and the α -particles are brought to coincide by delaying the impulse from the β -counter relative to that from the α -counter. The limitation of the method as regards the length of time which can be measured is the same as in the experiments of DUNWORTH and of ROTBLAT; an advantage, although not a fundamental one, is that the decay is observed directly and not by a differentiation as in the experiments mentioned previously.

The experiments.

The experimental arrangement is shown in Fig. 1. To the left of the figure, two counters are shown which are placed close together with their mica windows facing one another. Between the counters, the source is placed, a speck of active deposit from Radium emanation supported on an aluminium foil; the thickness of the foil was 6 mg per cm^2 , that of the windows was 3.5 mg per cm^2 . With this arrangement, one of the counters will count the β -particles from RaB and RaC, but no α -particles; the other one responds to both α - and β -particles. The counters are described in a paper by Miss H. LEVI.¹

With the thickness of the aluminium foil chosen, the β -counter will respond to most of the β -particles from both RaB and RaC; in agreement with this, it was found that the α -counter counted about 50 per cent more than the β -counter.

To the right in Fig. 1 is shown the Rossi stage which needs no further explanation. The resolving time was $7.5 \cdot 10^{-5}$ sec and was kept constant throughout the experiments. The resolving time was determined by counting the number of chance coincidences; the exact knowledge of the resolving time is without influence on the results, if only it is kept constant as will appear later.

The delay of the impulse from the β -counter, which is necessary to obtain coincidences, is effected by the circuits in the middle of Fig. 1; actually, both the β - and the α -kicks are de-

¹ Acta Physiol. Scand. **2**, 311, 1941.

layed by a certain amount, and it is the difference which enters into the measurements. The delay circuits D_1 and D_2 are shown in detail in Fig. 2. This circuit is known as a multivibrator; the mode of operation is well-known, and only for the sake of completeness it may be mentioned here. The circuit contains two valves which are coupled tightly together in such a way that, when the circuit is undisturbed, one valve is always "closed"

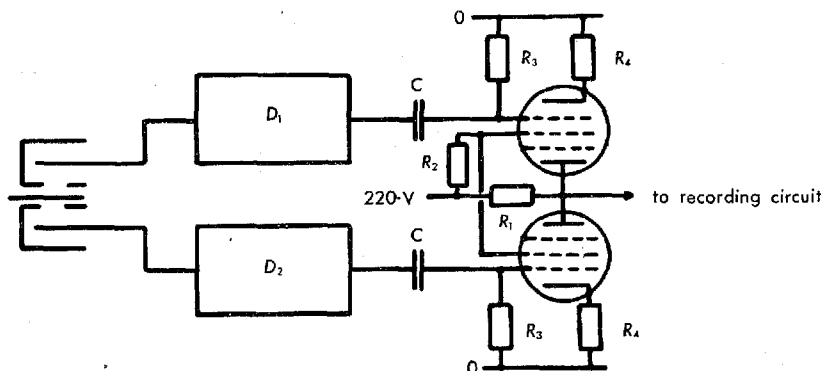

Fig. 1

D_1 D_2 delay circuits
(see fig. 2)

$$R_1 = 1.0 \text{ M}\Omega$$

$$R_2 = 0.5 \text{ ''}$$

$$R_3 = 0.1 \text{ ''}$$

$$R_4 = 200 \Omega$$

$$C = 25 \text{ cm}$$

Valves:
Philips AF 7

and the other valve is "open". A small negative impulse on the grid of the open valve will cause an increase in the anode potential of this valve. This increase is coupled to the grid of the second valve through the condenser C_2 with the result that the anode potential of the second valve decreases. This decrease in turn is transferred to the grid of the first valve, etc. The process continues until the first valve is closed and the second is open. When a stage is reached, where the anode and grid potentials have attained nearly constant values, the circuit quickly returns to its normal state by a process which is the reverse of the one just described. The time interval between the arrival of the primary impulse and the return of the system to its normal state is determined by the condenser C_2 , the anode resistance of the first valve and the grid leak of the second valve and may be varied within wide limits by varying C_2 .

The negative impulses delivered by the delay stages are transferred to the Rossi stage. By introducing a difference in the delay of the impulses from the α - and the β -counter, the Rossi stage records a coincidence when a β - and an α -particle are emitted with a time difference which is determined by the delay circuits. The impulses delivered by the α - and the β -counters were counted separately by scale-of-sixteen circuits; these are not shown in the figure.

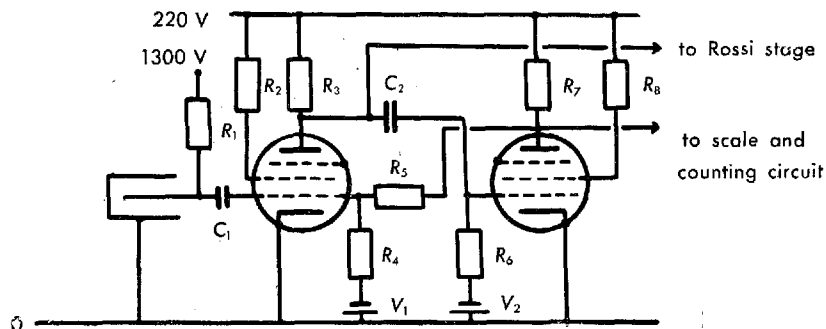

Fig. 2

$R_1 = 1.0 M\Omega$	$R_5 = 1.0 \Omega$	$V_1 = -75 V$
$R_2 = 0.2 \text{ »}$	$R_6 = 0.5 \text{ »}$	$V_2 = -20 V$
$R_3 = 0.2 \text{ »}$	$R_7 = 0.5 \text{ »}$	$C_1 = 50 \text{ cm}$
$R_4 = 0.5 \text{ »}$	$R_8 = 0.2 \text{ »}$	$C_2 = \begin{cases} 300 \text{ cm in the } \alpha\text{-delayer} \\ \text{Variable } > 300 \text{ cm in the } \beta\text{-delayer} \end{cases}$

Both valves: Philips AF 7

The measurements.

The delay circuit connected to the α -counter was kept unchanged during the measurements. By varying the condenser C_2 of the second delay circuit, different time intervals between the emission of the α - and the β -particles, which caused a coincidence, could be introduced. It was found that the delay varied very nearly linearly with the condenser C_2 . For each value of the condenser C_2 , the delay imparted to the β -impulse relative to the α -impulse was measured by connecting the output from the delay circuits through condensers to one pair of plates of a cathode ray oscillograph, the other pair of plates being connected to the usual sweep arrangement. A large number of genuine coincidences was produced by placing the counters close together

with their windows facing one another and irradiating with γ -rays. When a coincidence occurred, the deflections from the counters showed up separately as two peaks on the screen of the oscillograph. By suitably adjusting the sweep frequency, the two peaks could be brought to coincide. When this was the case, the time difference between the two deflections was equal to a whole number of periods of the sweep frequency; the sweep frequency itself was then determined by comparison with a known frequency; actually, a multiple of the frequency of the city mains was used. The only adjustment necessary for the measurement being to bring two peaks on the screen of the oscillograph to coincide, the determination of the delay could easily be made with an accuracy better than 1 per cent.

Among the factors determining the number of delayed coincidences actually counted, the solid angle of the beam of particles entering the counters should be chosen as high as possible. Actually, the counters were placed directly on one another with the source foil clamped between them.

The number of chance coincidences increases with the square of the source strength, while the number of genuine coincidences increases with the first power of the source strength, so that an upper limit is given for the strength of the source which can be used with advantage. In the experiments, the number of particles counted by the α - and the β -counters usually was about 2400 and 1600 per minute at the beginning of the experiment.

If the resolving time of the Rossi stage is τ , coincidences are counted over an interval of time equal to 2τ . The number of coincidences is thus proportional to τ , so that τ should be chosen as high as possible. If, on the other hand, τ is large relative to the half period, details of the decay curve will be lost. In the experiments, τ was chosen equal to $7.5 \cdot 10^{-5}$ sec, except for the measurement of the first point of the decay curve for which τ was $1.2 \cdot 10^{-5}$ sec.

With a given value of τ , the delay of the β -impulse relative to that of the α -impulse must not be made smaller than τ , otherwise the time interval over which the coincidences are counted will be reduced, because the α -particle is always emitted after the β -particle. A further reason to exclude very small time intervals from measurements was that a rather large number

of genuine coincidences was always observed; there is doubt

This result shows that, for $\lambda t > 1$, the value of λ^* is smaller than λ , for $\lambda t < 1$, the reverse is the case. The difference, however, is rather insignificant; if, to obtain a quantitative estimate, ϵ is assumed equal to 0.1, the error in the determination of λ is less than 1 per cent, since λt never differs much from unity with the values of t used in the experiments,

Our thanks are due Professor NIELS BOHR for his continuous interest in our work.

Summary.

The decay constant of RaC' has been determined by a coincidence method. Active deposit from Radium emanation is placed between two counters which are screened in such a way that one counter counts β -particles, only, the other counts both α - and β -particles. By means of a multivibrator, the impulses from the β -counter are delayed relative to the impulses from the α -counter by an amount which is of the same order of magnitude as the mean lifetime of RaC'. Under these circumstances the emission of a β -particle from RaC and the subsequent emission of an α -particle from RaC' are observed as a coincidence. The number of coincidences as a function of the delay of the impulses from the β -counter shows an exponential decay over a time interval of about 4 half periods; for the half period is found $(1.55 \pm 0.05) \cdot 10^{-4}$ sec, in satisfactory agreement with the value obtained previously by ROTBLAT.

The method used in the present experiments is further discussed in relation to the method used by ROTBLAT, partly as regards the statistical errors arising from the counting, and partly as regards a systematic error which is likely to be present in ROTBLAT's experiments. The result of the discussion is that this systematic error, although undoubtedly present in ROTBLAT's experiments, is so small that it has hardly been of any influence on the results.