

Matematisk-fysiske Meddelelser
udgivet af
Det Kongelige Danske Videnskabernes Selskab
Bind **33**, nr. 4

Mat. Fys. Medd. Dan. Vid. Selsk. **33**, no. 4 (1961)

THE STRUCTURE OF BARIUM BROMIDE DIHYDRATE

BY

EVA BANG



København 1961
i kommission hos Ejnar Munksgaard

Synopsis

$\text{BaBr}_2 \cdot 2\text{H}_2\text{O}$ belongs to the space group $C2/c$. The unit cell contains 4 molecules. $a = 10.44_9 \text{ \AA}$, $b = 7.20_4 \text{ \AA}$, $c = 8.38_5 \text{ \AA}$, $\beta = 113^\circ 29'_2$. X-ray analysis by 2-dimensional Fourier methods shows $[\text{Ba}(\text{H}_2\text{O})_2]_\infty$ columns in the direction of the c -axis, placed in between buckled layers of bromine atoms. The structure shows features reminding of $\text{SrCl}_2 \cdot 6\text{H}_2\text{O}$. The shortest Ba-Ba distance is 4.44 \AA , only a little larger than found for the element. The distances Ba-Br are 3.41 \AA , and 3.49 - 3.52 \AA . The distances Ba- H_2O are 2.82 \AA and 3.00 \AA and Br- H_2O are 3.25 - 3.33 \AA and 3.60 \AA .

Introduction

Very few detailed structure determinations on hydrated simple metal halides have been reported in the literature: three fluorides, eight chlorides, and one bromide. Five belong to the group of alkaline earth halogenides: $\text{BaCl}_2 \cdot \text{H}_2\text{O}$, $\text{BaBr}_2 \cdot \text{H}_2\text{O}$, $\text{SrCl}_2 \cdot 6\text{H}_2\text{O}$, $\text{BaCl}_2 \cdot 2\text{H}_2\text{O}$ and $\text{SrCl}_2 \cdot 2\text{H}_2\text{O}$.

The monohydrates, investigated by electron diffraction^{1, 2} are isomorphous (Pmcn). They contain zig-zag chains of $\begin{array}{c} \text{H}_2\text{O} \quad \text{H}_2\text{O} \\ \diagdown \quad \diagup \\ \text{Ba} \quad \text{Ba} \quad \text{Ba} \end{array}$ where barium

has 2 water molecules and 7 halogen atoms and the water molecule has 2 barium and 7 halogen atoms as nearest neighbours. The structure consists of a net of halogen atoms where barium and water alternate in the holes.

In $\text{SrCl}_2 \cdot 6\text{H}_2\text{O}$ ³ (P321), we get a one-dimensional lattice complex of $[\text{Sr}(\text{H}_2\text{O})_6]_\infty$, where strontium has 9 water molecules as nearest neighbours and no chlorine. There are 2 types of water molecules, one has 2 chlorine and 2 barium, the other has 3 chlorine and 1 barium as nearest neighbours.

The dihydrates $\text{BaCl}_2 \cdot 2\text{H}_2\text{O}$ ⁴ (P2₁/n) and $\text{SrCl}_2 \cdot 2\text{H}_2\text{O}$ ⁵ (C2/c) contain infinite two-dimensional lattice complexes, where the cation has 4 chlorine and 4 water molecules as nearest neighbours in slightly different arrangements.

To get more information about the behaviour of the water and the structural differences in the hydrates of the alkaline earth halogenides the structure of $\text{BaBr}_2 \cdot 2\text{H}_2\text{O}$ has been investigated.

The crystal class of $\text{BaBr}_2 \cdot 2\text{H}_2\text{O}$ was shown to be 2/m by O. MÜGGE^{7, 8} and H. DUFET,⁹ and the crystals to be optically positive. They can be obtained by slow evaporation at room temperature and very often appear from the same batch with quite different habits: plates, rods, or needles after [001] with parallel extinction, needles after $[\bar{1}\bar{1}0]$ with oblique extinction. Twins occur very often and are difficult to recognize. The needles after $[\bar{1}\bar{1}0]$ usually are not twinned. The morphology has been very carefully described by O. MÜGGE,⁷ who used the deformation by pressure into twins to show

that the crystal class was monoclinic and not orthorhombic as suggested by C. RAMMELSBERG and others.^{10, 11}

The powder diagrams of the 3 dihydrates mentioned above show that $\text{BaBr}_2 \cdot 2\text{H}_2\text{O}$ is neither isomorphous with $\text{BaCl}_2 \cdot 2\text{H}_2\text{O}$ nor with $\text{SrCl}_2 \cdot 2\text{H}_2\text{O}$.

X-Ray Examination, Unit Cell, and Space Group

Preliminary axes were taken from oscillation and Weissenberg diagrams (camera 57.3 mm) and refined from powder diagrams (Table 1). The powder diagrams have been obtained by means of a Bradley 19 cm camera and a Guinier type focusing camera with Cu radiation.

The unit cell dimensions are

$$\begin{aligned} a &= 10.44_9 \pm .03 \text{ \AA} & b &= 7.20_4 \pm .02 \text{ \AA} & c &= 8.38_5 \pm .02 \text{ \AA}, \\ \beta &= 113.49 \pm .3^\circ. \end{aligned}$$

The angle between [100] and [102] is 90.18° .

The axial ratio $a : b : c$ calculated 1.450 : 1 : 1.164.

The axial ratio $a : b : c$ given by O. MÜGGE⁷ 1.44943 : 1 : 1.16559.

β angle (supplemental angle of β given above) from O. MÜGGE⁷ $66^\circ 30\frac{1}{2}'$.

The density 3.87_2 $_{18}^{12}$ gives 4.05 molecules pr. unit cell.

The Weissenberg diagrams were taken by multiple film technique, the intensities estimated visually. As the crystals easily are deformed by mechanical pressure no attempts to cut a small fragment have been made. No corrections for absorption and temperature factor have been applied as only O-layer lines have been used for the final calculations. The intensities from rotation round the b axis should be less accurate, as it is very difficult to find a crystal with a suitable cross-section in the a - c plane. The usual corrections for polarisation and Lorentz factor have been applied.

With the monoclinic setting given above, reflections were present only for $h + k = 2n$ and $h0l$ for $l = 2n$. $|F(hkl)| = |F(h\bar{k}l)|$. The possible space groups are Cc or $C2/c$.

Investigations into piezoelectricity for the crystals gave a negative result.* It should, however, be mentioned that piezo- and pyroelectricity have been reported in a paper from 1897.¹³ The possibility of a lack of symmetry centre will be discussed later in connection with the Patterson and electron density projections.

* Kindly performed by V. FRANK, dynamical method.

TABLE 1. Comparison of observed and calculated $\sin^2\theta$ values.

Indices	Estim. Int.	10^4 $\sin^2\theta$ obs.	10^4 $\sin^2\theta$ calc.	Indices	Estim. Int.	10^4 $\sin^2\theta$ obs.	10^4 $\sin^2\theta$ calc.
110	wm	0178	0179	$42\bar{1}$			
$11\bar{1}$	wm	0216	0216	$42\bar{2}$	dif	1341	1337
200		0259	0259	222			1370
111	vwv	0345	0344	$13\bar{2}$	dif		
002			0402	023			1376
$20\bar{2}$	m	0403		0404	$20\bar{4}$		
$11\bar{2}$			0453	420			1485
020	vw br	0458		0458	$51\bar{2}$	vw	1490
021	vwv	0559	0558	312	w	1497	1494
$31\bar{1}$			0605	$51\bar{1}$	w	1512	1512
310	vwv?	0688	0689	$33\bar{1}$			1521
$22\bar{1}$	wm	0700	0697	$31\bar{4}$	vw?	1529	1530
112			0710	$11\bar{4}$	w	1536	1534
$31\bar{2}$	vs	0715		0714	330		
220			0717	004			1614
022			0860	$40\bar{4}$			1615
$22\bar{2}$	m	0861		0862	$33\bar{2}$		
$11\bar{3}$	m	0891	0891	$42\bar{3}$	wm	1630	1627
202			0918	$51\bar{3}$			1630
$40\bar{2}$			0923	132	vw	1675	1673
221	wm	0948	0946	510			1733
311	wm	0996	0990	$13\bar{3}$			1808
$31\bar{3}$	vw	1024	1023	224	wm	1812	1811
400	ms	1039	1036	040			1833
130	ms	1093	1096	$42\bar{1}$			1852
$13\bar{1}$	m	1133	1132	331	vw	1910	1907
$22\bar{3}$	vwv	1235	1236	041			1934
131	vwv	1263	1261	$33\bar{3}$			1940
113			1277	402			1952
				$60\bar{2}$	m	1960	1961
				223	vw	2010	2007
				114			2044
				$51\bar{4}$	ms	2054	2055

The intensities applied in the calculations were taken from Weissenberg diagrams, where the crystals had the following dimensions:

Length along the rotation axis $[001]$.2 mm cross section $.01 \times .02$ mm².
 - - - - $[010]$.15 mm - - $.15 \times .3$ mm².
 - - - - $[1\bar{1}0]$.5 mm - - $.1 \times .1$ mm².

Patterson and Electron Projections

The Patterson and electron projections were calculated on a Hagg-Laurent-Frank machine.¹⁴ The results for the Patterson function projected on (001) and (010) by using observed $|F(hkl)|^2$ values are shown in figs. 1 and 2.

In case we have the space group $C2/c$ (No. 15 Int. Tab.) there are 8 atoms in the general position:

$$(0, 0, 0; \frac{1}{2}, \frac{1}{2}, 0) + x, y, z; \bar{x}, \bar{y}, \bar{z}; \bar{x}, y, \frac{1}{2} - z; x, \bar{y}, \frac{1}{2} + z.$$

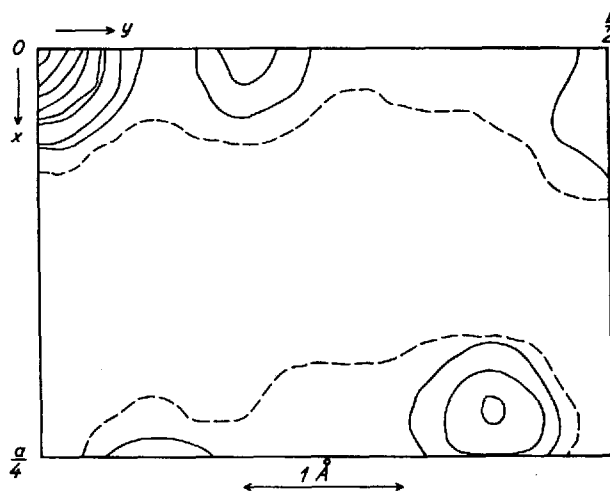

Fig. 1. Patterson projection on (001). Relative arbitrary scale.

The origin is at the symmetry centre of the glide plane.

The 4 Ba must lie in a special position. The positions denoted as c and d can be ruled out, as they both would give rise to a Ba–Ba vector peak in $0, \frac{1}{2}, \frac{1}{2}$, where the vector density is small for the [001] projection.

Assuming Ba at a symmetry centre $a: 0, 0, 0$ etc., or $b: 0, \frac{1}{2}, 0$, etc., we should expect no separate Ba–Ba and 16 Ba–Br vector peaks if Br is in the general position (8 in the (001) projection and 8 in the (010) projection). In case the Ba position is on the twofold axis $e: 0, y, 1/4$, etc., we should get 4 separate Ba–Ba and 16 Ba–Br vector peaks (16 in the (001) projection and 8 in the (010) projection).

In the projection on (010) the Ba–Ba vector peaks are bound to fall in $0, 0; 0, \frac{1}{2}$, etc. The strong peaks outside the axes must be the Ba–Br vector

peaks. If Ba has the x, z coordinates $0, 0$, the x, z coordinates of Br can be evaluated $(.21, .10)$, and thus most of the signs of the structure factors. In case Ba is in $e: 0, y, 1/4$, etc., the resulting projection will be the same except for a translation $1/4 c$.

The Patterson projection on (001) shows 8 strong peaks outside the axes

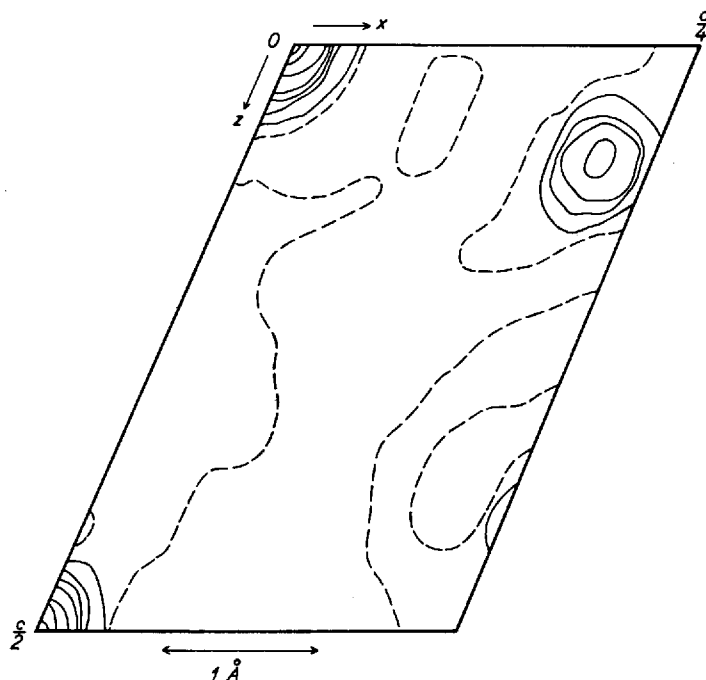

Fig. 2. Patterson projection on (010) . Relative arbitrary scale.

which should be taken as Ba-Br vector peaks. In case we have Ba in $0, y, 1/4$ the coordinates of the Ba and the Br atoms must have a correspondence that gives rise to superposed Ba-Br vector peaks in this projection.

The 4 Ba-Ba vector peaks in this case have the coordinates $0, 2y, \frac{1}{2}$, etc., and if the strongest peak outside the origin on the b axis is taken as a Ba-Ba vector peak ($y_{\text{Ba}} = .1$ and $y_{\text{Br}} = \frac{1}{2}$), we should only get 8 Ba-Br vector peaks and the coordinates of the Ba-Ba and the Br-Br vector peaks would correspond. On this assumption most of the signs could be evaluated and the electron density projection was calculated. This interpretation of the Patterson projection later turned out to lead to the correct structure.

TABLE 2. Atomic parameters in $\text{BaBr}_2 \cdot 2\text{H}_2\text{O}$.

	x	y	z
Ba	0	.101	.250
Br	.218	.476	.350
O	.01	.748	.445

As another interpretation of the Patterson projection on (001) the coordinates for the Ba atoms could be 0, 0, 0; etc. or 0, 0, 1/4, etc. The x, y coordi-

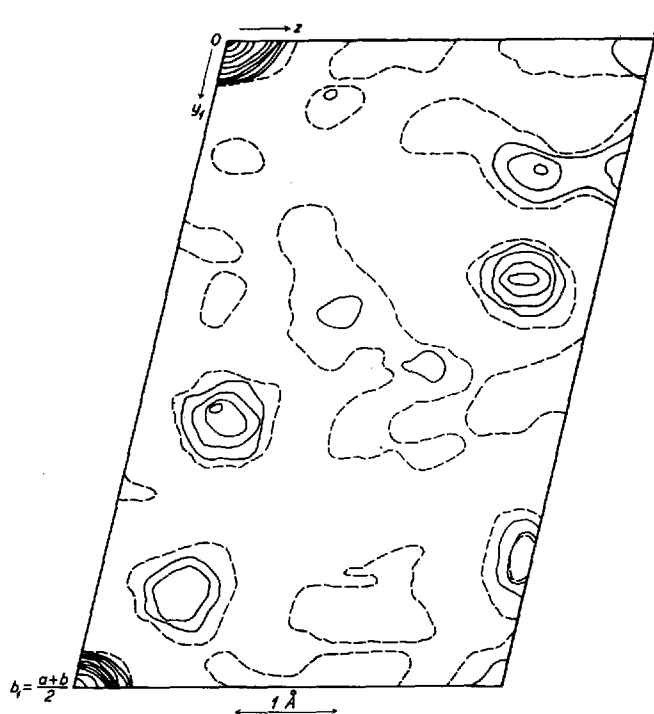

Fig. 3. Patterson projection on (110). Relative arbitrary scale.

nates for the Br atom were evaluated (.22, .40) and thus most of the signs of the structure factors. The calculated electron density projection and the agreement between observed and calculated F values were not bad. ($R = .3$). It will be shown later that this structure was wrong.

In case there is no symmetry centre the space group is Cc , as mentioned above. The number of atoms in the general position is 4 and the coordinates are

$$(0, 0, 0; \frac{1}{2}, \frac{1}{2}, 0;) + x, y, z; x, \bar{y}, \frac{1}{2} + z.$$

The origin is on the glide plane.

The 8 Br atoms must be coordinated in such a way that they give rise to only 8 Ba-Br vector peaks in the (010) and (001) Patterson projections. The combination of the 2 sets: x, y, z , etc., and \bar{x}, y, \bar{z} , etc., and the same relation between the Ba and Br y -coordinates as in the case C2/c fulfil this condition. The projections of this structure on (010) and (001) are the same as in the centrosymmetrical case and possible preliminary coordinates could be taken from the results mentioned above.

The projection of the structure along the $[1\bar{1}0]$ axis is noncentrosymmetrical. It turned out, however, that electron projections carried out for both space groups were of little help in distinguishing between the different possibilities at this stage of the structure investigations. The data were taken from a crystal needle showing oblique extinction. It was possible to coordinate the reciprocal net and the Patterson projection on $(1\bar{1}0)$ (fig. 3) throughout with the data from the crystals used before.

Only C2/c Ba in 0, 0, 0, etc., was cancelled out. The possible position of Ba is then 0, y , 1/4, etc., and of Br .22, y , .35, etc. The coordinates $y_{\text{Ba}} = 0.1$ and $y_{\text{Br}} = 0.5$ would be the most probable from a physical point of view as the Br-Br distance would be 3.8-4.2 Å, whereas $y_{\text{Ba}} = 0.0$ and $y_{\text{Br}} = 0.4$ would give a very short Br-Br distance 3.1-3.4 Å for both space groups. In the layer structure of AlBr₃ the shortest Br-Br distances are 3.59 Å¹⁶. $r_{\text{Br-}}$ is 1.95-1.96 Å (PAULING-GOLDSCHMIDT).

A generalized projection on (010) made it possible to distinguish between the cases mentioned above.

Generalized Projection on (010)

In the generalized projection the electron density function $\varrho(x, y, z)$ is modified by a weighting function $e^{2\pi iLz}$, where L is a constant value of Index 1. Examples and theory are given in the monographs by H. LIPSON and W. COCHRAN¹⁷ and by M. BUERGER.¹⁸

The generalized projection on (010) can be written

$$\varrho_K(x, z) = \int_0^1 \varrho(x, y, z) e^{2\pi iKy} b dz$$

or

$$\varrho_K(x, z) = C_K(x, z) + iS(x, z),$$

where

$$C_K(x, z) = \frac{b}{V} \sum_h \sum_l A(hKl) \cos 2\pi(hx + lz) + B(hKl) \sin 2\pi(hx + lz),$$

$$S_K(x, z) = \frac{b}{V} \sum_h \sum_l B(hKl) \cos 2\pi(hx + lz) - A(hKl) \sin 2\pi(hx + lz).$$

The real part $C_K(x, z)$ should approximately give the projection of the structure on (010) with the electron density of the n th atom multiplied by

Fig. 4. $C(x, z)$ Fig. 5. $S(x, z)$

Fig. 4 and fig. 5. Generalized projections $C(x, z)$ and $S(x, z)$ on (010). $K = 1$. Negative areas are hatched. Relative arbitrary scale.

$\cos 2\pi Ky$ and the imaginary part $S_K(x, z)$ the electron density multiplied by $\sin 2\pi Ky$.

As mentioned above, the possible position of Ba was $0, y, 1/4$ and of Br $.22, y, .35$. The possible y -coordinates for Ba and Br were $y_{Ba} = 0.0, y_{Br} = 0.4$ or $y_{Ba} = 0.1, y_{Br} = 0.5$.

The projections were carried out for $K = 1$ ($C2/c$). Owing to the symmetry of the space group the calculation work was small. The calculated $S_K(x, z)$ and $C_K(x, z)$ clearly showed that $y_{Ba} = 0.0, y_{Br} = 0.4$ was ruled out, as the $S_K(x, z)$ projection in this case was quite confused. Only the projections for $y_{Ba} = 0.1, y_{Br} = 0.5$ are given here (figs. 4 and 5; cf. fig. 7). The $S(x, z)$ projection shows a small bromine peak which indicates that y_{Br} is a little different from 0.5.

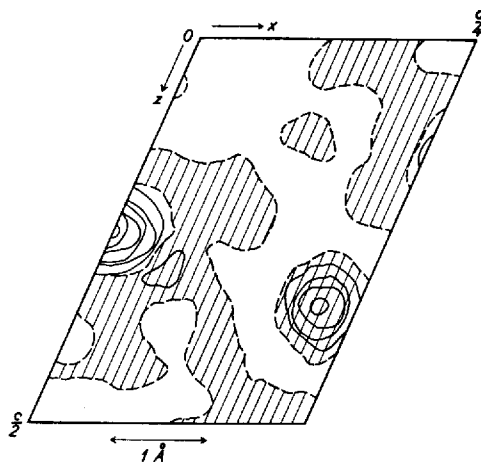
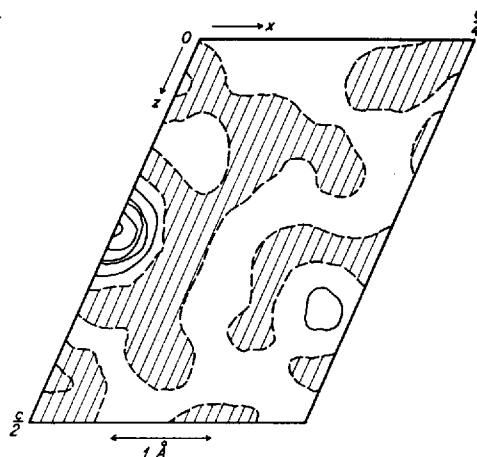
This information is in agreement with the Patterson projection along $(1\bar{1}0)$, but could not be obtained from it on account of overlapping peaks.

Position of the Water. Refinement of the Structure

The structure found was a layer structure with Ba in the ac -plane on the twofold axes and a bromine layer in between. As the Patterson projection on

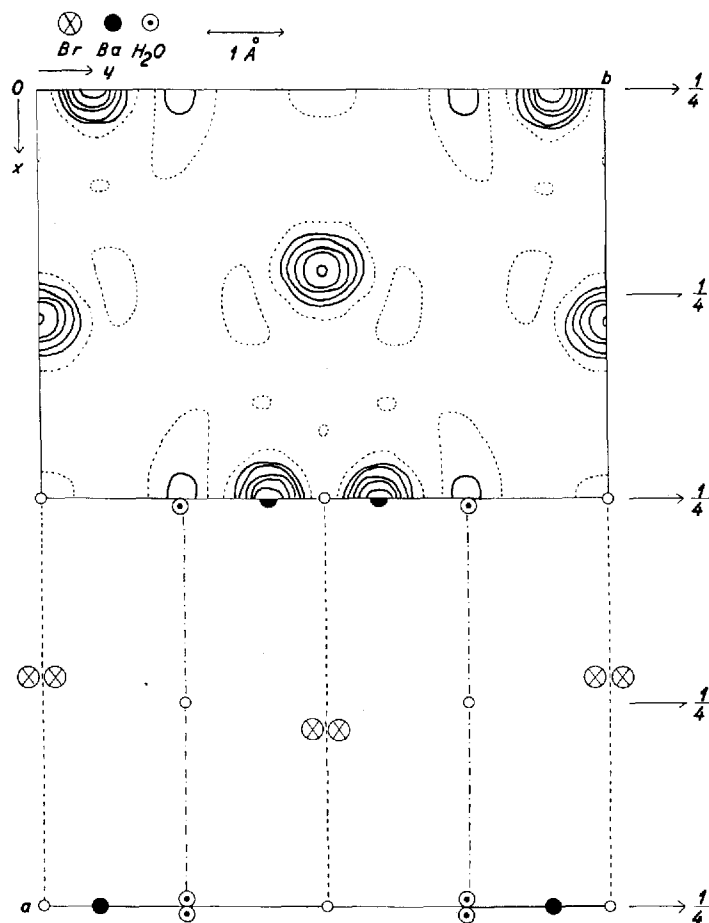

Fig. 6. Electron projection on (001). Relative arbitrary scale for electron density.

(001) showed vector density along the yz planes and as the water molecules from a packing point of view cannot be placed near the bromine layer, the next highest peak outside the origin on the y -axis was taken as a Ba-0 vector peak. The y_0 could easily be deduced. The x_0 should be very near to 0.0 and z_0 was taken to 0.5 from a geometrical consideration together with the electron density projection and the 2 generalized projections on (010).

The refining of the structure was carried out by difference syntheses using $F_{\text{obs.}} - F_{\text{calc.}}$ for 0-layer line projections along $[001]$, $[010]$ and $[1\bar{1}0]$. The calculated and observed structure factors were scaled for each projection by plotting $\log_{10} \frac{F_{\text{obs.}}}{F_{\text{calc.}}}$ against $\sin^2\theta$. The resulting coordinates are given in

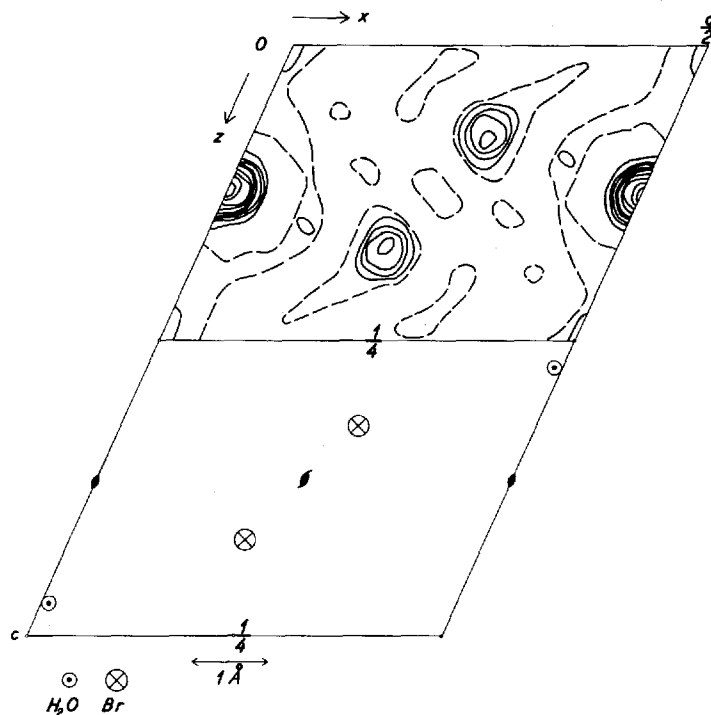

Fig. 7. Electron projection on (010). Ba on the twofold axis. Relative arbitrary scale for electron density.

Table 2 and the calculated and observed F -values in Table 3–7. The electron projections are given in figs. 6–8.

Neither further refining nor a calculation for the noncentrosymmetrical case $y_{\text{Br}} = 0.5$ should be made unless better experimental data have been obtained.

Description of the Structure

The interatomic distances between nearest neighbours are given in Table 7.

Each Ba atom is surrounded by 2 Ba, 6 Br, and 4 H_2O (fig. 9). The 2 Ba

atoms have a separation a little larger than found for the element. The 4 water molecules are nearly lying in the plane of the Ba atoms. 2 have the shortest distance, 2 are a little farther away, the difference being of the same magnitude as found for the 2 types of water molecules in $\text{SrCl}_2 \cdot 6\text{H}_2\text{O}^3$. Four Br are lying on one side of the Ba atom nearly in a plane perpendicular

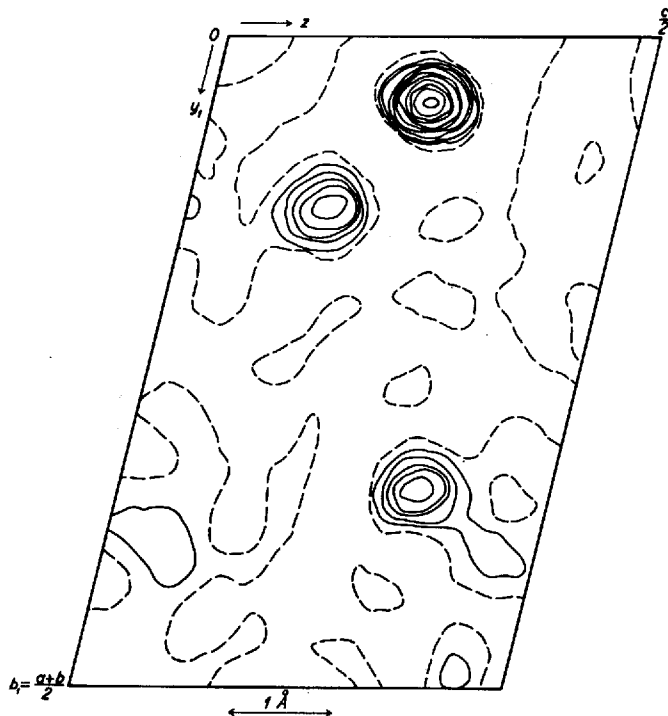

Fig. 8. Electron projection on $(1\bar{1}0)$. Relative arbitrary scale for electron density.

to the plane of the Ba atoms in a slightly longer distance than contact. 2 Br are on the other side of the Ba atom perpendicular to the plane of Ba atoms and the plane of the 4 Br atoms.

The water molecule has 2 Ba and 5 Br atoms as nearest neighbours (fig. 10). The size and the difference in distance to the Ba atoms are mentioned above. Two of the Br atoms are in distance of contact on one side of the Ba-H₂O-Ba group, 3 on the opposite side, 2 having distance of contact, 1 being a little farther away.

The Br atom is surrounded by 3 Ba, 5 H₂O, and 1 Br. One Ba has distance of contact, 2 are a little farther away. Four H₂O are tetrahedrally

TABLE 3. Comparison of calculated and observed structure factors.
Rotation [001] 0-layer line.

h	k	F_{calc}	$ F_{\text{obs}} $	h	k	F_{calc}	$ F_{\text{obs}} $
2	0	8	13	9	3	$\overline{38}$	30
4	0	88	103	0	4	15	13
6	0	29	31	2	4	$\overline{58}$	58
8	0	36	36	4	4	1	
10	0	47	40	6	4	$\overline{32}$	32
1	1	29	31	8	4	$\overline{22}$	22
3	1	69	59	1	5	41	45
5	1	8	10	3	5	$\overline{18}$	22
7	1	66	52	5	5	54	47
9	1	$\overline{9}$		7	5	$\overline{6}$	
11	1	45	31	0	6	$\overline{8}$	15
0	2	57	42	2	6	$\overline{51}$	56
2	2	$\overline{47}$	51	4	6	$\overline{13}$	17
4	2	35	37	6	6	$\overline{34}$	30
6	2	$\overline{9}$	9	1	7	$\overline{11}$	10
8	2	3		3	7	2	
10	2	15	16	5	7	$\overline{20}$	14
1	3	$\overline{23}$	26	0	8	25	17
3	3	12	10	2	8	2	
5	3	$\overline{45}$	43	4	8	20	11
7	3	22	23	1	9	16	19

coordinated round the Br atom at a distance of contact, 1 H₂O at a slightly greater distance. The Br atom has a distance slightly greater than twice the ionic radius.

The structure could be described as consisting of flat $[\text{Ba}(\text{H}_2\text{O})_2]_{\infty}$ columns parallel to the *c*-axis having the Ba atoms at a distance slightly greater than found for the element. The distance between the Sr atoms in the $[\text{Sr}(\text{H}_2\text{O})_6]_{\infty}$ complex in SrCl₂·6H₂O is of the same size. Each $[\text{Ba}(\text{H}_2\text{O})_2]_{\infty}$ column is surrounded by 6 parallel Br-columns (fig. 11). The Br in the columns form a row just a little buckled, with the Br-Br distance within the same size as the Cl-Cl distance in the Cl columns. Each Br contacts 3 $[\text{Ba}(\text{H}_2\text{O})_2]_{\infty}$ columns through 1 Ba contact to one column, and 2 H₂O contacts to each of the other 2 columns. There is a difference from SrCl₂·6H₂O, where Cl only has water contacts to the $[\text{Sr}(\text{H}_2\text{O})_6]_{\infty}$ complex.

Another one-dimensional complex $[\text{Ba}(\text{H}_2\text{O})]_{\infty}$ occurs in the monohydrates BaCl₂·H₂O¹ and BaBr₂·H₂O² as zig-zag lines of Ba-H₂O-Ba-H₂O-

TABLE 4. Comparison of calculated and observed structure factors.
Rotation [010] 0-layer line.

h l	F _{calc}	F _{obs}	h l	F _{calc}	F _{obs}
2 $\overline{10}$	1	8	2 $\overline{2}$	$\overline{46}$	35
4 $\overline{10}$	$\overline{50}$	37	4 $\overline{2}$	$\overline{13}$	12
6 $\overline{10}$	$\overline{18}$	18	6 $\overline{2}$	$\overline{70}$	53
8 $\overline{10}$	$\overline{28}$	20	8 $\overline{2}$	5	17
0 $\overline{8}$	35	34	10 $\overline{2}$	$\overline{63}$	78
2 $\overline{8}$	8	11	12 $\overline{2}$	1	8
4 $\overline{8}$	56	43	2 0	8	13
6 $\overline{8}$	$\overline{8}$		4 0	93	100
8 $\overline{8}$	54	44	6 0	29	44
10 $\overline{8}$	1		8 0	35	49
12 $\overline{8}$	35	36	10 0	46	60
0 $\overline{6}$	$\overline{5}$		12 0	6	5
2 $\overline{6}$	58	49	2 2	1	
4 $\overline{6}$	$\overline{34}$	36	4 2	$\overline{71}$	77
6 $\overline{6}$	$\overline{28}$	35	6 2	11	27
8 $\overline{6}$	$\overline{56}$	48	8 2	58	83
10 $\overline{6}$	$\overline{1}$		10 2	$\overline{1}$	7
12 $\overline{6}$	$\overline{60}$	52	2 4	63	56
0 $\overline{4}$	4		7 4	30	38
2 $\overline{4}$	90	58	6 4	23	32
4 $\overline{4}$	$\overline{7}$	9	8 4	46	69
6 $\overline{4}$	71	67	2 6	$\overline{68}$	64
8 $\overline{4}$	10		4 6	3	
10 $\overline{4}$	35	41	6 6	$\overline{52}$	55
12 $\overline{4}$	31	40	2 8	27	31
0 $\overline{2}$	$\overline{58}$	43	4 8	9	15

in layers of halogen atoms. Here the distance of contact Ba-halogen is found between the layers, and the shortest distance halogen-H₂O in the layers. The Ba-Ba distance is much greater than found for the element.

[Sr(H₂O)₂]_∞ columns occur in the structure of SrCl₂·2H₂O⁵, but the arrangement in the complex is quite different from the arrangement in the [Ba(H₂O)₂]_∞ complex in BaBr₂·2H₂O, and the distance between the Sr atoms is much greater than for the element. BaCl₂·2H₂O⁴ shows infinite 2-dimensional Ba-H₂O complexes.

A description analogous to that given in (4) and (5) for SrCl₂·2H₂O and BaCl₂·2H₂O, of BaBr₂·2H₂O as a layer structure, where the layers are neutral complexes of [BaBr₂·2H₂O]_∞, does not fit so well here. The neutral

TABLE 5. Comparison of calculated and observed structure factors.
Rotation [010] 1-layer line $k = 1$.

h	l	F_{calc}	$ F_{\text{obs}} $	h	l	F_{calc}	$ F_{\text{obs}} $
1	$\overline{10}$	$\overline{15}$	$\overline{17}$	5	$\overline{3}$	$\overline{34}$	25
3	$\overline{10}$	$\overline{36}$	26	7	$\overline{3}$	$\overline{28}$	26
1	$\overline{9}$	14		9	$\overline{3}$	$\overline{20}$	31
3	$\overline{9}$	17	16	11	$\overline{3}$	$\overline{24}$	35
5	$\overline{9}$	19	18	13	$\overline{3}$	$\overline{22}$	16
7	$\overline{9}$	14		1	$\overline{2}$	18	20
9	$\overline{9}$	21	11	3	$\overline{2}$	$\overline{88}$	50
1	$\overline{8}$	50	47	5	$\overline{2}$	3	
3	$\overline{8}$	3		7	$\overline{2}$	$\overline{47}$	70
5	$\overline{8}$	32	34	9	$\overline{2}$	32	42
7	$\overline{8}$	28	23	11	$\overline{2}$	$\overline{12}$	12
9	$\overline{8}$	8		13	$\overline{2}$	$\overline{38}$	20
11	$\overline{8}$	42	45	1	$\overline{1}$	31	18
1	$\overline{7}$	$\overline{16}$	17	3	$\overline{1}$	12	9
3	$\overline{7}$	$\overline{26}$	26	5	$\overline{1}$	26	36
5	$\overline{7}$	$\overline{16}$	14	7	$\overline{1}$	11	15
7	$\overline{7}$	$\overline{21}$	18	9	$\overline{1}$	18	32
9	$\overline{7}$	$\overline{13}$	17	11	$\overline{1}$	12	11
11	$\overline{7}$	$\overline{17}$	13	1	0	30	20
1	$\overline{6}$	$\overline{55}$	57	3	0	69	69
3	$\overline{6}$	9		5	0	$\overline{7}$	15
5	$\overline{6}$	$\overline{65}$	65	7	0	65	82
7	$\overline{6}$	14	10	9	0	$\overline{12}$	23
9	$\overline{6}$	$\overline{46}$	42	11	0	33	44
11	$\overline{6}$	$\overline{14}$	18	1	1	$\overline{22}$	25
1	$\overline{5}$	14	13	3	1	$\overline{26}$	26
3	$\overline{5}$	19	21	5	1	$\overline{25}$	46
5	$\overline{5}$	9	14	7	1	$\overline{16}$	25
7	$\overline{5}$	20	23	9	1	$\overline{23}$	41
9	$\overline{5}$	10		11	1	$\overline{13}$	10
11	$\overline{5}$	18	23	1	2	76	70
13	$\overline{5}$	11	8	3	2	$\overline{4}$	
1	$\overline{4}$	13	12	5	2	$\overline{39}$	55
3	$\overline{4}$	34	30	7	2	$\overline{30}$	50
5	$\overline{4}$	47	39	9	2	$\overline{6}$	
7	$\overline{4}$	0		11	2	$\overline{43}$	22
9	$\overline{4}$	68	75	1	3	26	28
11	$\overline{4}$	9	15	3	3	35	38
13	$\overline{4}$	45	26	5	3	19	30
1	$\overline{3}$	41	40	7	3	22	35
3	$\overline{8}$	$\overline{29}$	30	9	3	17	22

(to be continued)

TABLE 5 (continued).

h	l	F_{calc}	$ F_{obs} $	h	l	F_{calc}	$ F_{obs} $
1	4	63	58	1	6	$\overline{11}$	17
3	4	$\overline{9}$	14	3	6	$\overline{25}$	24
5	4	60	70	5	6	$\overline{33}$	38
7	4	$\overline{5}$	9	1	7	25	25
9	4	38	26	3	7	16	15
1	5	$\overline{13}$	14	5	7	19	18
3	5	$\overline{16}$	17	1	8	$\overline{7}$	
5	5	$\overline{9}$	13	3	8	$\overline{48}$	44
7	5	$\overline{16}$	22	1	9	$\overline{18}$	22

TABLE 6. Comparison of calculated and observed structure factors.
Rotation $[1\overline{1}0]$ 0-layer line.

h	k	l	F_{calc}	$ F_{obs} $	h	k	l	F_{calc}	$ F_{obs} $
1	1	$\overline{10}$	$\overline{15}$	14	5	5	$\overline{5}$	$\overline{23}$	33
2	2	$\overline{10}$	20	10	6	6	$\overline{5}$	$\overline{25}$	34
1	1	$\overline{9}$	14	10	7	7	$\overline{5}$	3	5
2	2	$\overline{9}$	36	28	1	1	$\overline{4}$	14	
3	3	$\overline{9}$	24	20	2	2	$\overline{4}$	54	46
1	1	$\overline{8}$	52	45	3	3	$\overline{4}$	$\overline{10}$	13
2	2	$\overline{8}$	$\overline{7}$		4	4	$\overline{4}$	$\overline{60}$	58
3	3	$\overline{8}$	$\overline{27}$	24	5	5	$\overline{4}$	$\overline{21}$	34
4	4	$\overline{8}$	$\overline{4}$		6	6	$\overline{4}$	$\overline{4}$	14
5	5	$\overline{8}$	$\overline{20}$	22	7	7	$\overline{4}$	$\overline{19}$	14
1	1	$\overline{7}$	$\overline{16}$	17	1	1	$\overline{3}$	$\overline{44}$	37
2	2	$\overline{7}$	$\overline{30}$	30	2	2	$\overline{3}$	$\overline{28}$	30
3	3	$\overline{7}$	$\overline{36}$	48	3	3	$\overline{3}$	$\overline{17}$	18
4	4	$\overline{7}$	$\overline{8}$		4	4	$\overline{3}$	$\overline{42}$	46
5	5	$\overline{7}$	16	14	5	5	$\overline{3}$	$\overline{10}$	
1	1	$\overline{6}$	$\overline{55}$	58	6	6	$\overline{3}$	44	48
2	2	$\overline{6}$	$\overline{26}$	30	7	7	$\overline{3}$	25	25
3	3	$\overline{6}$	41	43	1	1	$\overline{2}$	18	19
4	4	$\overline{6}$	25	33	2	2	$\overline{2}$	$\overline{25}$	29
5	5	$\overline{7}$	4		3	3	$\overline{2}$	$\overline{28}$	28
6	6	$\overline{7}$	30	31	4	4	$\overline{2}$	47	56
7	7	$\overline{7}$	19	14	5	5	$\overline{2}$	54	61
1	1	$\overline{5}$	14	15	6	6	$\overline{2}$	7	13
2	2	$\overline{5}$	21	21	7	7	$\overline{2}$	2	
3	3	$\overline{5}$	48	56	1	1	$\overline{1}$	31	25
4	4	$\overline{5}$	33	37	2	2	$\overline{1}$	55	32

TABLE 6. (Continued).

h	k	l	F _{calc}	F _{obs}	h	k	l	F _{calc}	F _{obs}
3	3	$\bar{1}$	24	27	4	4	3	9	
4	4	$\bar{1}$	20	32	5	5	3	$\bar{16}$	17
5	5	$\bar{1}$	22	15	6	6	3	2	
6	6	$\bar{1}$	$\bar{23}$	32	0	0	4	4	
7	7	$\bar{1}$	$\bar{44}$	40	1	1	4	65	56
1	1	0	29	31	2	2	4	28	29
2	2	0	$\bar{46}$	55	3	3	4	$\bar{42}$	37
3	3	0	17	28	4	4	4	$\bar{24}$	30
4	4	0	1		5	5	4	$\bar{5}$	
5	5	0	$\bar{55}$	57	6	6	4	$\bar{28}$	30
6	6	0	$\bar{33}$	36	1	1	5	$\bar{12}$	14
7	7	0	$\bar{7}$		2	2	5	$\bar{19}$	22
1	1	1	$\bar{23}$	16	3	3	5	$\bar{42}$	42
2	2	1	$\bar{61}$	41	4	4	5	$\bar{29}$	28
3	3	1	$\bar{37}$	44	5	5	5	20	20
4	4	1	2		0	0	$\bar{6}$	$\bar{5}$	
5	5	1	$\bar{10}$	12	1	1	6	$\bar{12}$	24
6	6	1	$\bar{4}$		2	2	6	$\bar{42}$	32
7	7	1	43	34	3	3	6	9	
0	0	2	$\bar{58}$	37	4	4	6	46	35
1	1	2	$\bar{89}$	44	1	1	7	26	27
2	2	2	10		2	2	7	19	20
3	3	2	36	30	3	3	7	14	16
4	4	2	4		4	4	7	30	24
5	5	2	23	32	0	0	8	35	29
6	6	2	40	31	1	1	8	$\bar{8}$	
1	1	3	26	27	2	2	8	14	11
2	2	3	38	37	3	3	8	18	8
3	3	3	54	44	1	1	9	$\bar{18}$	16

layers, which must be taken parallel to (110) or (100), where the $[\text{Ba}(\text{H}_2\text{O})_2]_\infty$ columns have their shortest distance, are penetrated by bromine ions from adjacent layers. For a layer in the first case every second bromine atom in the columns parallel to [001] belongs to an adjacent layer, and for a layer in the second case every second bromine column in the buckled bromine layer parallel to (100) belongs to an adjacent layer (figs. 6 and 11).

In many of the structures of salt hydrates earlier investigated, especially the hydrated oxy-salts, the water molecule is surrounded by 3-4 neighbours: 1-2 metal ions and 2-3 anions. This simple rule can neither be applied for the hydrated alkaline earth halogenides nor for the hydrated halogenides of

TABLE 7. Interatomic distances between nearest neighbours (Frequency).
The atoms are numbered by means of the sequence given in Int. Tab. for
the general position of $C2/c$ (No. 15).

		Distance <i>in Å</i>	From PAULING Ionic Radii	Radius sum From GOLDSCHMIDT Ionic Radii
Ba ₁	Ba ₂ (2)	4.44		4.347 ¹⁹
	Br ₁ (2)	3.41	3.30	
	Br ₇ (2)	3.49		
	Br ₆ (2)	3.52		
	O ₄ (2)	2.82	2.82	
	O ₁ (2)	3.00		
Br ₁	Ba ₁ (1)	3.32		3.39
	Ba ₂ (1)	3.49		
	Ba ₄ (1)	3.52		
	Br ₆ (1)	4.00	3.90	
	Br ₇ (1)	4.14		
	Br ₃ (1)	4.18		
	Br ₄ (1)	4.21		
	O ₁ (1)	3.25	3.29	
	O ₅ (1)	3.27		
	O ₃ (1)	3.31		
	O ₆ (1)	3.33		
	O ₄ (1)	3.60		
	O ₂ (1)	3.81		
O ₁	Ba ₂ (1)	2.82		
	Ba ₁ (1)	3.00		
	Br ₁ (1)	3.25		
	Br ₅ (1)	3.27		
	Br ₃ (1)	3.31		
	Br ₆ (1)	3.33		
	Br ₄ (1)	3.50		
	Br ₂ (1)	3.81		

the transition elements.¹⁵ In the first case it is only valid for $\text{SrCl}_2 \cdot 6\text{H}_2\text{O}$, and $\text{BaCl}_2 \cdot 2\text{H}_2\text{O}$. The number and positions of the atoms surrounding the water molecule given above for $\text{BaBr}_2 \cdot 2\text{H}_2\text{O}$ are not incompatible with the results for the group as a whole. It is not possible from the obtained data to say anything about the positions of the hydrogen atoms.

It should be mentioned that the direction of the $[\text{Ba}(\text{H}_2\text{O})_2]_\infty$ columns

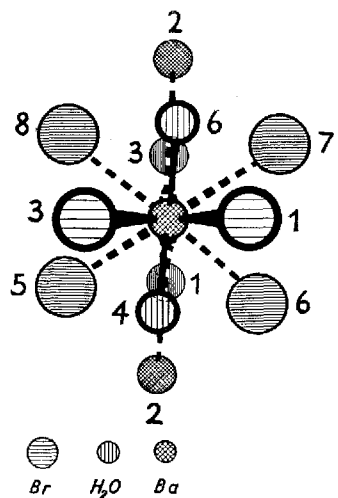

Fig. 9. Barium and surrounding atoms. Viewed in the direction along the b -axis. Shortest distances solid lines. Longer distances dashed lines. Lower lying atoms have a dark hatching and thin circumference.

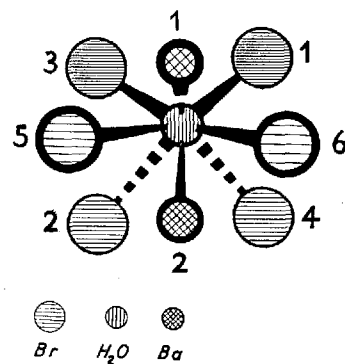

Fig. 10. Water molecule and surrounding atoms. Viewed in the direction along the b -axis. Signatures as in fig. 9.

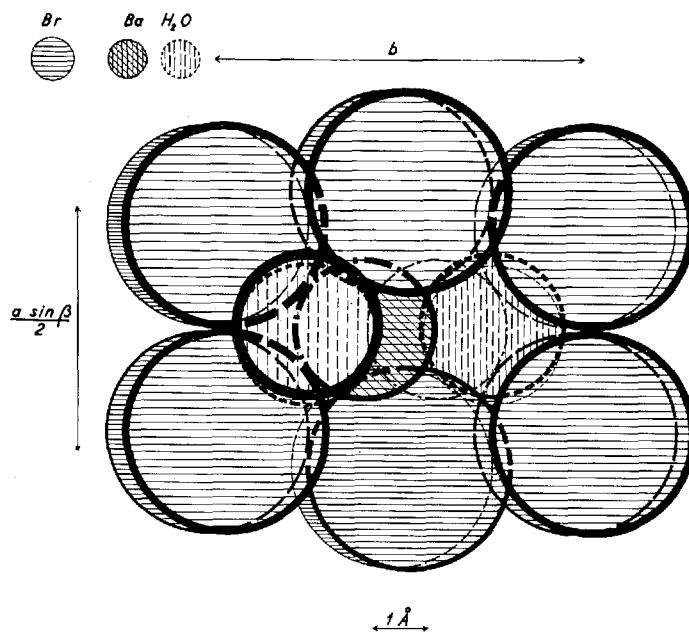

Fig. 11. $[\text{Ba}(\text{H}_2\text{O})_2]_\infty$ column and surrounding Br columns viewed along the c -axis. Lower layers have dark hatching and a thin circumference.

[001] and the packing of the columns could be connected to the occurrence of the 2 different needle axes [001] and [110].

The deformation by pressure in the direction of the c -axis and the formation of twins are understandable if it is considered that the $[\text{Ba}(\text{H}_2\text{O})_2]_\infty$ columns lie in this direction (fig. 12). $\text{SrCl}_2 \cdot 6\text{H}_2\text{O}$ ²⁰ shows cleavage per-

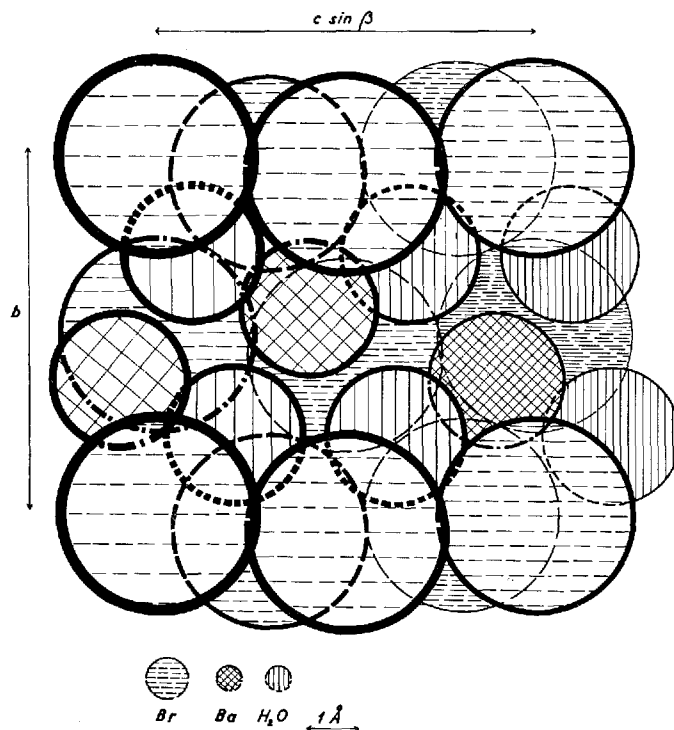

Fig. 12. $[\text{Ba}(\text{H}_2\text{O})_2]_\infty$ column and surrounding bromine atoms viewed along the a -axis. Signatures as in fig. 11.

pendicular to the $[\text{Sr}(\text{H}_2\text{O})_6]_\infty$ columns. It has not been possible to show cleavage for $\text{BaBr}_2 \cdot 2\text{H}_2\text{O}$.

Table 4 gives the shortest halogen-water distances for some halogen hydrates. The distances for $\text{BaBr}_2 \cdot \text{H}_2\text{O}$ compare well with the other distances in the table. The mean value of the mean values of the distances for each crystal gives $\text{Br}-\text{H}_2\text{O} = 3.29 \text{ \AA}$ and $\text{Cl}-\text{H}_2\text{O} = 3.15 \text{ \AA}$. This gives an empirical radius for H_2O against halogen ions $r_{\text{H}_2\text{O}}^{\text{an}} \begin{matrix} (P) \\ (G) \end{matrix} 1.34 \text{ \AA}$ for Cl and $r_{\text{H}_2\text{O}}^{\text{an}} \begin{matrix} (P) \\ (G) \end{matrix} 1.33 \text{ \AA}$ for Br.

TABLE 8.

	Cl-H ₂ O			
	Distance in Å			
BaCl ₂ , H ₂ O ¹	3.14	3.24		
BaCl ₂ , 2H ₂ O ⁴	3.17	3.18	3.19	3.22
SrCl ₂ , 2H ₂ O ³	3.10			
SrCl ₂ , 6H ₂ O ⁵	3.10	3.17		
CoCl ₂ , 2H ₂ O ²¹	3.18	3.19		
FeCl ₂ , 4H ₂ O ²²	3.07	3.18	3.22	
AlCl ₃ , 6H ₂ O ⁶	3.1			
HCl, H ₂ O ²³	2.95			
Adeninhydrochloridehemihydrate ²⁴	3.12			
	Br-H ₂ O			
BaBr ₂ , H ₂ O ²	3.29	3.32		
BaBr ₂ , 2H ₂ O.....	3.25	3.27	3.31	3.33
11-Aminoundecanoicacidhydrobromide- hemihydrate ²⁵	3.17	3.38		
Codeinhydrobromide Dihydrate ²⁶	3.27			
Strychninehydrobromide Dihydrate ²⁷	3.15	3.30	3.41	

Acknowledgements

I wish to thank Professor, dr. phil. A. TOVBORG JENSEN for his interest in this work and mag. scient. CHR. KN. MØLLER for help and discussions.

References

1. Z. G. PINSKER, B. K. VAJNSTEJN. Zur Fiz. Khim **23** p. 1058 (1949).
2. B. K. VAJNSTEJN, Z. G. PINSKER. Zur Fiz. Khim **24** p. 432 (1950).
3. A. TOVBORG JENSEN, Mat. Fys. Medd. Dan. Vid. Selsk. **17** No. 9 (1940).
4. — — — — — — — — — — **20** No. 5 (1942).
5. — — — — — — — — — — **22** No. 3 (1945).
6. — Krystallinske Salthydrater, Copenhagen (1948).
7. O. MÜGGE, Neues Jahrbuch f. Min. **1** p. 130 (1889).
8. — — — — — — — — — — **1** p. 71 (1898).
9. H. DUFET, Bull. Soc. Fr. Min. XXVI p. 67 (1903)
10. C. RAMMELSBERG, Pogg. An. **55** p. 232 (1842).
11. Handl. Sitzb. Akad. Wien XXXII p. 244 (1858).
12. Heidweyller, Zeit. Phys. **3** p. 320 (1920).
13. W. G. HANKEL, H. LINDENBERG, Zeit. Krist. **27** p. 516 (1897).
14. V. FRANK, J. Sci. Instr. **34** p. 310 (1957).
15. A. F. Wells, Quart. Rev. **8** p. 380 (1954).
16. P. A. RENES, C. A. Mac. Gillavry, Rec. Trav. Chim. **64**, p. 275 (1945).
17. H. LIPSON, W. Cochran, The Crystalline State, vol. III.
— Determination of Crystal Structures London (1953).
18. MARTIN J. BUERGER, Crystal-Structure analysis, New York (1960).
19. W. KLEMM, G. MIKA, Z. Anorg. Chem. **248** p. 155 (1941).
20. A. EPPLER, Zeit. Krist. **30** p. 129 (1899).
21. B. K. VAJNSTEJN, Doklady Akad. Nauk. S.S.S.R. **68** p. 301 (1949).
22. BRUCE R. PENFOLD, J. A. Gregor, Acta Cryst. **12** p. 850 (1959).
23. KU YOON, GENE B. CARPENTER, Acta Cryst. **12** p. 17 (1959).
24. JUNE M. BROOMHEAD, Acta Cryst. **1** p. 324 (1947).
25. G. A. SIM, Acta Cryst. **8** p. 833 (1955).
26. JUNE M. LINDSEY, U. U. BARNES, Acta Cryst. **8** p. 227 (1955).
27. J. H. ROBERTSON, C. A. BEEVERS, Acta Cryst. **4** p. 270 (1951).

